

Modulating globe valve actuator for 2-way and 3-way globe valves

- Actuating force 1000 N
- Nominal voltage AC/DC 24 V
- Control Modulating DC (0)2...10 V
- Nominal stroke 20 mm
- Actuating time 35 s / 20 mm
- Design life SuperCaps: 15 years

**Technical data**

<b>Electrical data</b>	Nominal voltage	AC/DC 24 V
	Nominal voltage frequency	50/60 Hz
	Nominal voltage range	AC 19.2...28.8 V / DC 21.6...28.8 V
	Power consumption in operation	4.5 W
	Power consumption in rest position	1.5 W
	Power consumption for wire sizing	9 VA
	Connection supply / control	Terminals with cable 1 m, 4 x 0.75 mm <sup>2</sup> (Terminal 4 mm <sup>2</sup> )
	Parallel operation	Yes (note the performance data)
<b>Functional data</b>	Actuating force motor	1000 N
	Positioning signal Y	DC 0...10 V
	Positioning signal Y note	Input impedance 100 kΩ
	Operating range Y	DC 2...10 V
	Position feedback U	DC 2...10 V
	Position feedback U note	Max. 0.5 mA
	Emergency setting position	Actuator spindle 0...100%, adjustable (POP rotary button)
	Position accuracy	5% absolute
	Manual override	Gear disengagement with push-button
	Nominal stroke	20 mm
	Actuating time	35 s / 20 mm
	Actuating time emergency control function	35 s / 20 mm
	Adaption setting range	manual (automatic on first power-up)
	Sound power level motor	60 dB(A)
	Sound power level emergency control position	60 dB(A)
Position indication	Mechanically, 5...20 mm stroke	
<b>Safety</b>	Protection class IEC/EN	III Safety extra-low voltage
	Degree of protection IEC/EN	IP54
	EMC	CE according to 2004/108/EC
	Certification IEC/EN	IEC/EN 60730-1 and IEC/EN 60730-2-14
	Mode of operation	Type 1.AA
	Rated impulse voltage supply / control	0.8 kV
	Control pollution degree	3
	Ambient temperature	0...50°C
	Non-operating temperature	-40...80°C
	Ambient humidity	95% r.h., non-condensing
Maintenance	Maintenance-free	
<b>Weight</b>	Weight approx.	1.7 kg
<b>Terms</b>	Abbreviations	POP = Power off position / emergency setting position CPO = Controlled power off / controlled emergency control function PF = Power fail delay time / bridging time

**Safety notes**



- This device has been designed for use in stationary heating, ventilation and air conditioning systems and is not allowed to be used outside the specified field of application, especially in aircraft or in any other airborne means of transport.
- Only authorised specialists may carry out installation. All applicable legal or institutional installation regulations must be complied during installation.
- The switch for changing the direction of motion and so the closing point may be adjusted only by authorised specialists. The direction of motion is critical, particularly in connection with frost protection circuits.
- The device may only be opened at the manufacturer's site. It does not contain any parts that can be replaced or repaired by the user.
- The device contains electrical and electronic components and is not allowed to be disposed of as household refuse. All locally valid regulations and requirements must be observed.

**Product features**

**Principle of operation**

The actuator is connected with a standard modulating signal of DC 0...10 V and moves to the position defined by the positioning signal at the same time as the integrated capacitors are loaded. Interrupting the supply voltage causes the valve to be moved to the selected emergency setting position (POP) by means of stored electrical energy.

**Pre-charging time (start up)**

The capacitor actuators require a pre-charging time. This time is used for charging the capacitors up to a usable voltage level. This ensures that, in the event of an electricity interruption, the actuator can move at any time from its current position into the preset emergency setting position (POP). The duration of the pre-charging time depends mainly on how long the power was interrupted.

Typical pre-charging time

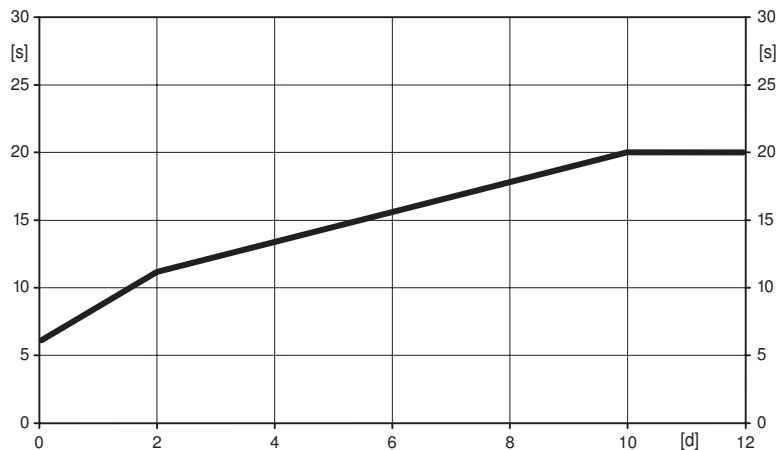

[d] = Electricity interruption in days  
[s] = Pre-charging time in seconds

**Delivery condition (capacitors)**

The actuator is completely discharged after delivery from the factory, which is why the actuator requires approximately 20 s pre-charging time before initial commissioning in order to bring the capacitors up to the required voltage level.

**Simple direct mounting**

Simple direct mounting on the globe valve by means of form-fit hollow clamping jaws. The actuator can be rotated by 360° on the valve neck.

**Manual override**

Manual control with push-button possible - temporary. The gear is disengaged and the actuator decoupled for as long as the button is pressed. The stroke can be adjusted by using a hexagon socket screw key (4 mm), which is inserted into the top of the actuator. The stroke spindle extends when the key is rotated clockwise.

**High functional reliability**

The actuator is overload protected, requires no limit switches and automatically stops when the end stop is reached.

**Combination valve/actuator**

Refer to the valve documentation for suitable valves, their permitted medium temperatures and closing pressures.

**Product features**

- Position indication** The stroke is indicated mechanically on the bracket with tabs. The stroke range adjusts itself automatically during operation.
- Home position** Factory setting: Actuator spindle is retracted. When valve-actuator combinations are shipped, the direction of motion is set in accordance with the closing point of the valve. The first time the supply voltage is switched on, i.e. at the time of commissioning, the actuator carries out an adaption, which is when the operating range and position feedback adjust themselves to the mechanical setting range. The actuator then moves into the position defined by the positioning signal.
- Direction of rotation switch** When actuated, the direction of stroke switch changes the running direction in normal operation. The direction of stroke switch has no influence on the emergency setting position (POP) which has been set.
- Adaption and synchronisation** An adaption can be triggered manually by pressing the „Adaption“ button. Both mechanical end stops are detected during the adaption (entire setting range). The actuator then moves into the position defined by the positioning signal.
- Emergency setting position (POP) rotary knob** The «Emergency setting position» rotary knob can be used to adjust the desired emergency setting position (POP). In the event of an electricity interruption, the actuator will move into the selected emergency setting position, taking into account the bridging time (PF) of 2 s which was set ex-works.

**Accessories**

	Description	Type
Electrical accessories	Auxiliary switch, 2 x SPDT, add-on	S2A-H

**Electrical installation**

**Notes**

- Connection via safety isolating transformer.
- Parallel connection of other actuators possible. Observe the performance data.
- Direction of stroke switch factory setting: Actuator spindle retracted.

**Wiring diagrams**

AC/DC 24 V, modulating

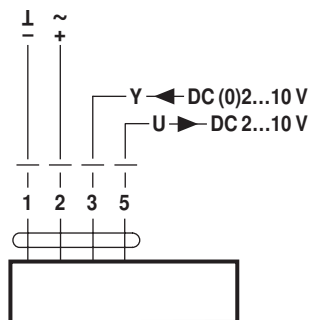

**Cable colours:**  
 1 = black  
 2 = red  
 3 = white  
 5 = orange

Override control (frost protection circuit)

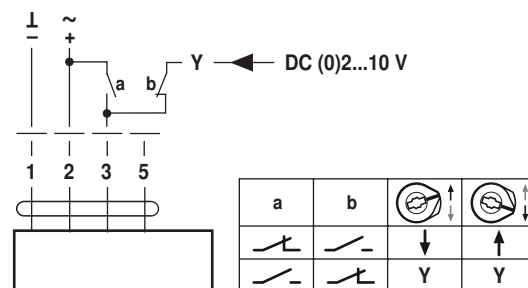

Operating controls and indicators

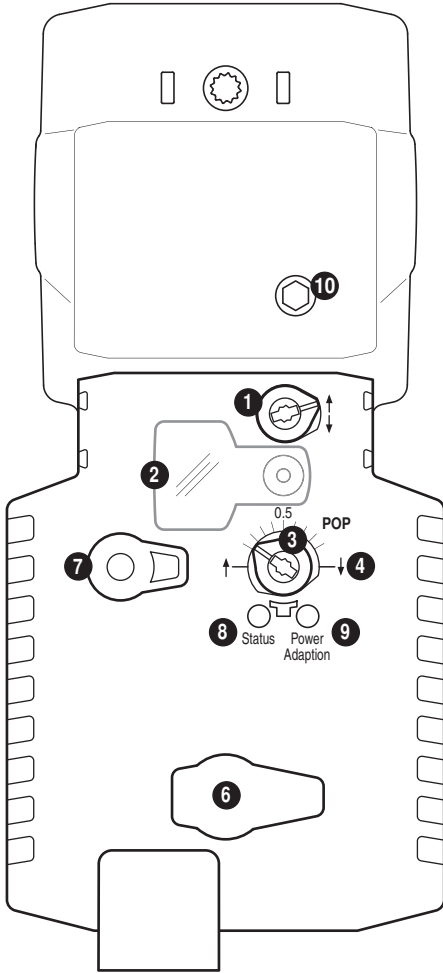

- 1 Direction of stroke switch**  
Switch over: Direction of stroke changes
- 2 Cover, POP button**
- 3 POP button**
- 4 Scale for manual adjustment**
- 6** (No function)
- 7 Gear disengagement button**  
Press button: Gear disengaged, motor stops, manual operation possible  
Release button: Gear engaged, standard mode

LED displays		Meaning / function
<b>8</b> yellow	<b>9</b> green	
Off	On	Operation OK
Off	Flashing	POP function active
On	Off	Pre-charging time SuperCap, fault SuperCap or wiring error in supply
Off	Off	Not in operation
On	On	Adaptation procedure running

- 9 Push-button (LED green)**  
Press button: Triggers stroke adaptation, followed by standard mode
- 10 Manual override**  
Clockwise: Actuator spindle extends  
Counterclockwise: Actuator spindle retracts

Emergency position (POP) setting

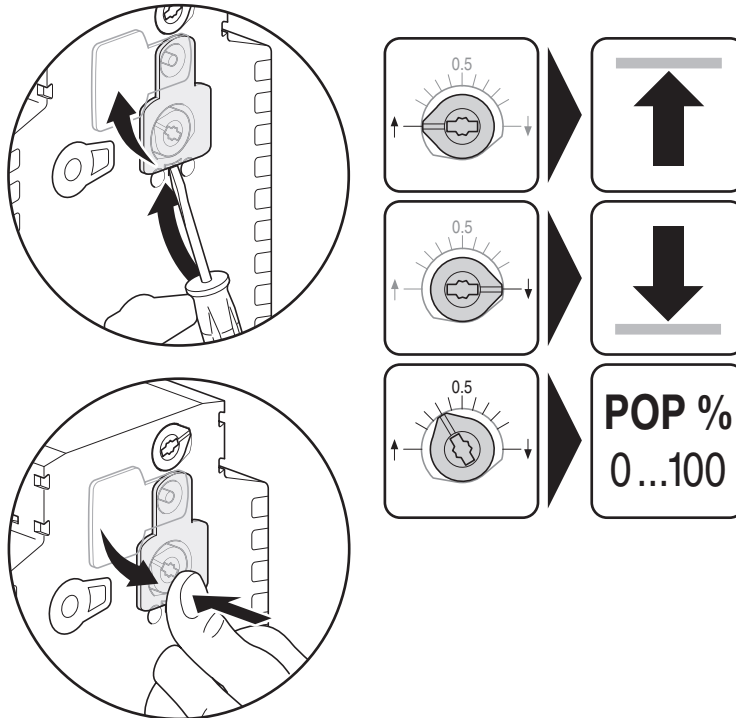

## Dimensions [mm]

## Dimensional drawings

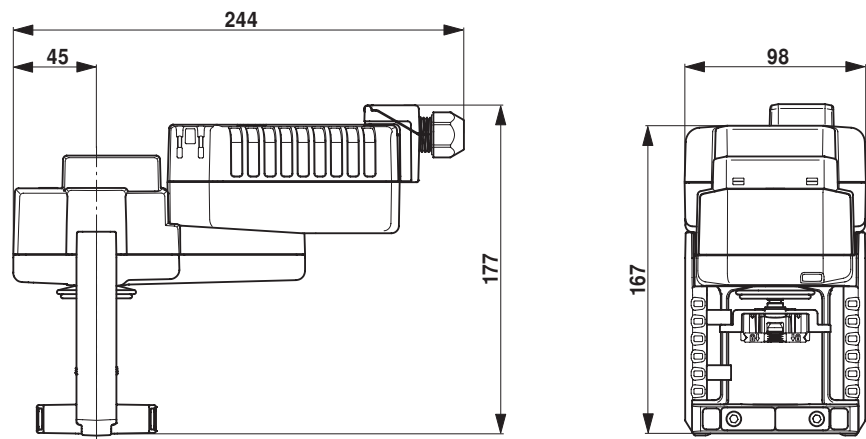

## Further documentation

- Overview Valve-actuator combinations
- Data sheets for globe valves
- Installation instructions for actuators and/or globe valves
- Notes for project planning 2-way and 3-way globe valves
- General notes for project planning